

Straight 3/4" Pitch Belting

106 CL (106 Closed)



Description

- 3/4 inch pitch
- Solid top surface
- Built to USDA & FDA standards
- Bi-directional
- Connecting rod diameter = 0.188 inch (4.8 mm)
- Standard belt width increments = 3/4 inches (19.1 mm) nominal, starting from 3 inches (76.2 mm)
- Material selection may affect belt width - please contact your local partner for actual dimensions

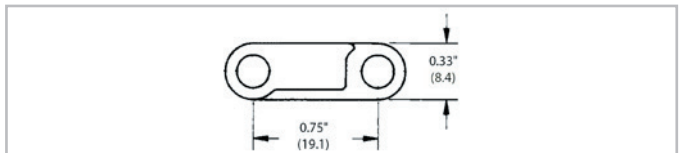
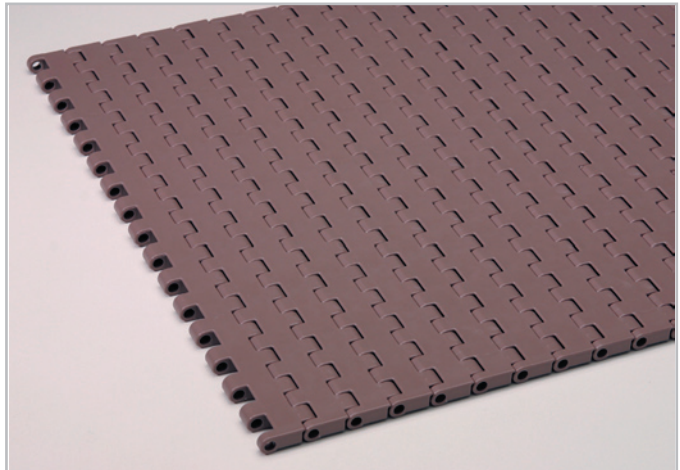

Belt data

Belt material		PP	POM	POM L
Rod material		PP		
Nominal tensile strength F_N^1 straight run	N/m	376	753	753
	lb/ft	5487	10989	10989
Temperature range	°C	10 - 99	10 - 93	10 - 93
	°F	50 - 210	50 - 200	50 - 200
Belt weight m_b	kg/m ²	4.9	6.8	6.8
	lb/sqft	1.00	1.40	1.40
Standard belt color		gray	gray/white	brown

Additional belt colors and materials available, abrasive resistant Nylon (Polyamide) rods available – contact your local partner.

All data are approximate values according to KVP Inc. standard operating procedures.

Belt accessories

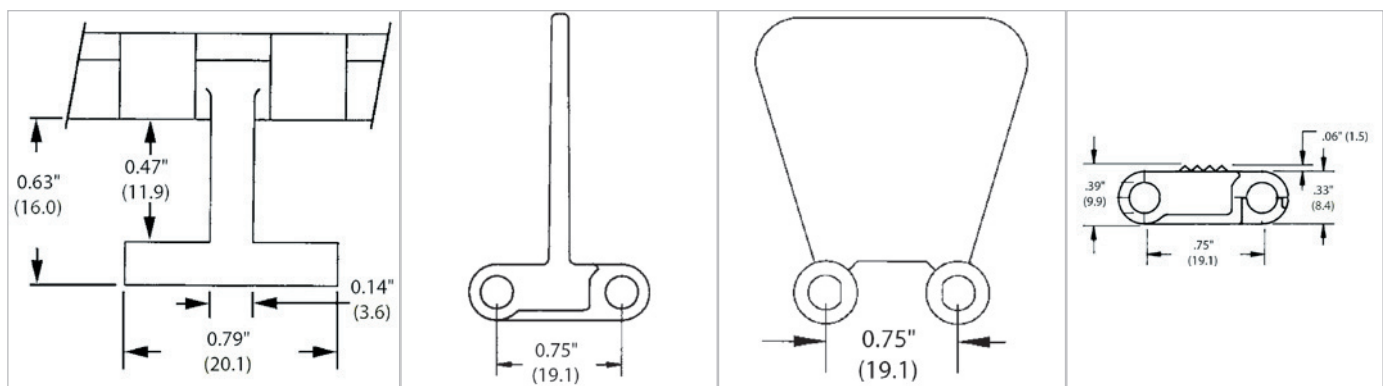

Hold down tabs

Flights

Standard flights are available in 1-1/2" (38.1 mm) and 3" (76.2 mm) heights.

Sideplates

Sideplates are available in 1" (25.4 mm) and 1-1/2" (38.1 mm) heights.

Rough Top - rubber insert

Straight 3/4" Pitch Belting

106 CL (106 Closed)



Product liability, application considerations

If the proper selection and application of Habasit products are not recommended by an authorized Habasit sales specialist, the selection and application of Habasit products, including the related area of product safety, are the responsibility of the customer.

All indications / information are recommendations and believed to be reliable, but no representations, guarantees, or warranties of any kind are made as to their accuracy or suitability for particular applications. The data provided herein are based on laboratory work with small-scale test equipment, running at standard conditions, and do not necessarily match product performance in industrial use. New knowledge and experiences can lead to modifications and changes within a short time without prior notice.

BECAUSE CONDITIONS OF USE ARE OUTSIDE OF HABASIT'S AND ITS AFFILIATED COMPANIES CONTROL, WE CANNOT ASSUME ANY LIABILITY CONCERNING THE SUITABILITY AND PROCESS ABILITY OF THE PRODUCTS MENTIONED HEREIN. THIS ALSO APPLIES TO PROCESS RESULTS / OUTPUT / MANUFACTURING GOODS AS WELL AS TO POSSIBLE DEFECTS, DAMAGES, CONSEQUENTIAL DAMAGES, AND FURTHER-REACHING CONSEQUENCES.