

Straight 1.1" Pitch Belting

F51 (1/2" x 1" Flat Wire)



Description

- 1.1 inch pitch
- 69% open area — 1/2" x 1" (12.7 mm x 25.4 mm)
- Built to USDA & FDA standards
- Connecting rod diameter = 0.145 inch (3.7 mm)
- Standard belt width increments = 1.33 inches (33.8 mm) nominal, starting from 4 inches (101.6 mm)
- Material selection may affect belt width — please contact your local partner for actual dimensions
- Bi-directional — contact your local partner

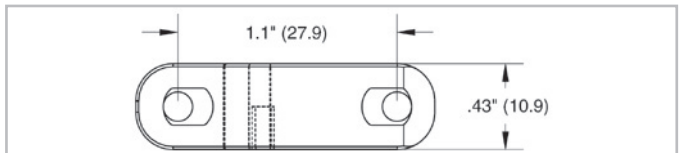
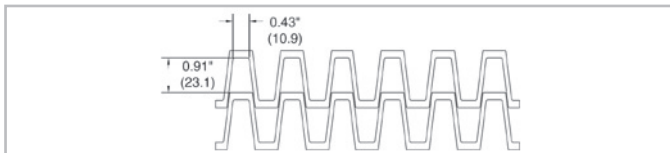
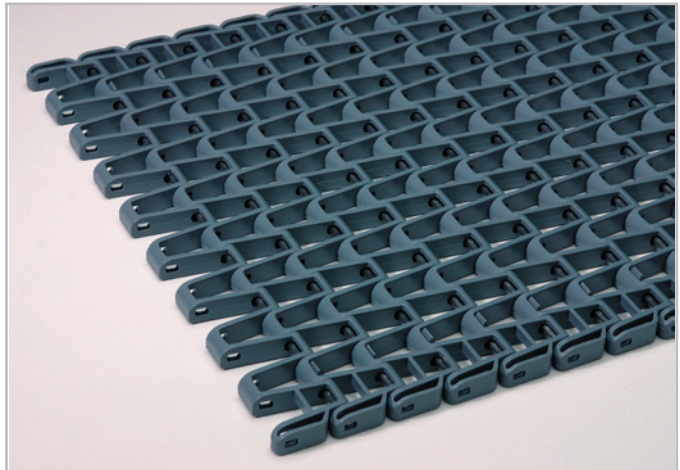

Belt data

Belt material		PP	PP +GR	POM	Nylon (PA 612)	Nylon (PA +GF)
Rod material			PP		Nylon (PA)	Stainless Steel
Nominal tensile strength F_N^1 straight run	N/m	4378	4378	8756	7297	8766
	lb/ft	300	300	600	500	600
Temperature range	°C	10 - 99	10 - 99	10 - 93	-40 - 118	-40 - 196
	°F	50 - 210	50 - 210	50 - 200	-40 - 245	-40 - 385
Belt weight m_B	kg/m ²	3.0	3.0	4.4	3.7	4.5
	lb/sqft	0.62	0.62	0.90	0.76	0.93
Standard belt color		gray/white	gray	blue	beige	red

Additional belt colors and materials available, abrasive resistant Nylon (Polyamide) and stainless steel rods available - contact your local partner.

Thermal endurance of heat stabilized Nylon 66 may vary based on exposure to elevated temperatures.

All data are approximate values according to KVP Inc. standard operating procedures.

Belt accessories

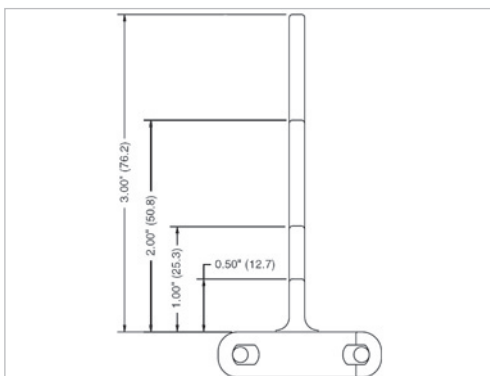

Flights
Standard flights are available in 1/2", 1", 2" and 3" heights.

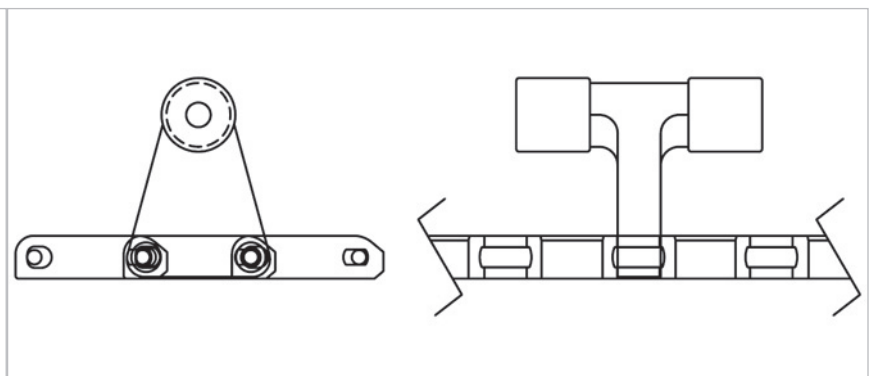

Hanging roller assembly

Straight 1.1" Pitch Belting

F51 (1/2" x 1" Flat Wire)



Product liability, application considerations

If the proper selection and application of Habasit products are not recommended by an authorized Habasit sales specialist, the selection and application of Habasit products, including the related area of product safety, are the responsibility of the customer.

All indications / information are recommendations and believed to be reliable, but no representations, guarantees, or warranties of any kind are made as to their accuracy or suitability for particular applications. The data provided herein are based on laboratory work with small-scale test equipment, running at standard conditions, and do not necessarily match product performance in industrial use. New knowledge and experiences can lead to modifications and changes within a short time without prior notice.

BECAUSE CONDITIONS OF USE ARE OUTSIDE OF HABASIT'S AND ITS AFFILIATED COMPANIES CONTROL, WE CANNOT ASSUME ANY LIABILITY CONCERNING THE SUITABILITY AND PROCESS ABILITY OF THE PRODUCTS MENTIONED HEREIN. THIS ALSO APPLIES TO PROCESS RESULTS / OUTPUT / MANUFACTURING GOODS AS WELL AS TO POSSIBLE DEFECTS, DAMAGES, CONSEQUENTIAL DAMAGES, AND FURTHER-REACHING CONSEQUENCES.